



EMBRAGUES NEUMATICOS MULTIDISCO DIRECTOS

LPR





PNEUMATIC STATIC-CYLINDER MULTI-DISK CLUTCHES

The excellent technical, construction and operating characteristics of this type of clutch have resulted in a wide range of applications in the manufacturing industry.

Its simple design includes a center hub, a disk pack, two radial bearings and a fixed cylinder with a working piston

Air under pressure enters through the external bore «A», a solution which permits the elimination of complicated channeling and allows several clutches to be mounted on the same shaft.

A series of disk separating springs, generates sufficient axial pressure to allow the quick return of the piston to its neutral position, impacting minimally on the working thrust.

The fixed piston transmits its power to push the rotating disks through a rugged radial bearing.

The stroke of the piston and the thrust springs allow disk-wear take-up, thus eliminating the need for adjustment. Furthermore, mounting of the springs between the disks prevents most of the dragging when in the neutral position, allowing the installation of the clutch in a vertical position, in the presence of very sensitive kinematic or where greater uncoupling precision is required.

This series of pneumatic multi-disk clutches has been engineered to run dry, thanks to the choice of using a combination of bronze/steel disks and sealed bearings that actually allow you to work without lubrication. Variants with transmission sleeve (LPR) and elastic coupling (LPG) further extend the already impressive range of possible applications for these clutches.

To ensure that the clutch operates correctly, the supply pressure must always remain constant: so, it would be better to provide for an accumulation tank, in order to compensate any pressure changes.

Also, the control valve must be mounted as close as possible to the supply bore located on the cylinder and must be equipped with a blow-off device to discharge the piston and, as a result, to quickly disengage the transmission

MOUNTING

When mounting, please follow our instructions and examples. The working cylinder must be anchored, but not blocked, by means of a bracket or pin engaged on one of the three 120°milled spots on the working cylinder itself; this bracket is to be hooked onto the most convenient milled spot, in relation to the air supply bore, making sure that the working cylinder has some radial and axial play.

LPR

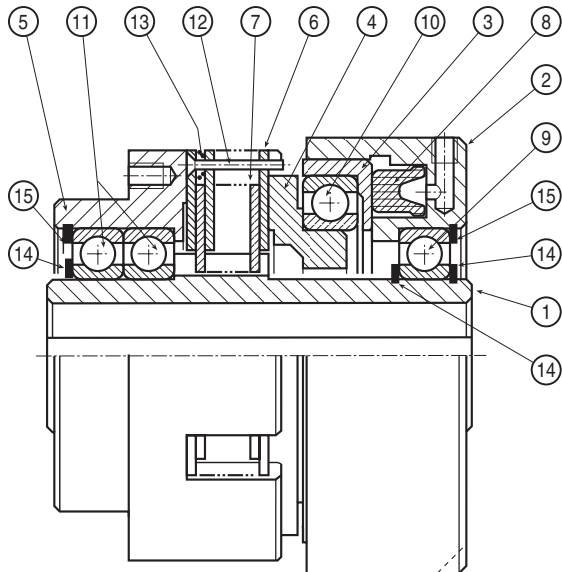

LPG

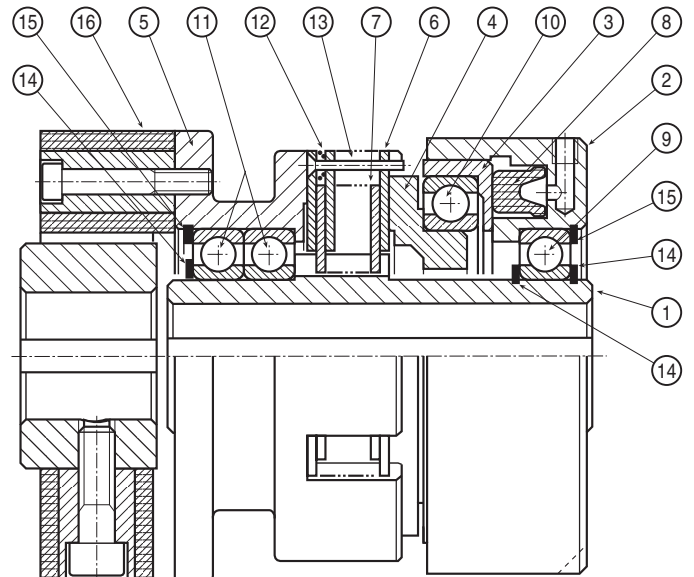

PARTS LIST

1. CENTRAL HUB
2. CYLINDER
3. PISTON
4. THRUST RING
5. TRANSMISSION HUB
6. OUTER DISK
7. INNER DISK
8. SEAL RING
9. HUB BEARING
10. PISTON BEARING
11. TRANSMISSION HUB BEARING
12. DISK SEPARATING SPRING
13. SPRING GUIDE PIN
14. OUTER SAFETY RING
15. INNER SAFETY RING
16. FLEXIBLE COUPLING

EXAMPLES OF MOUNTING

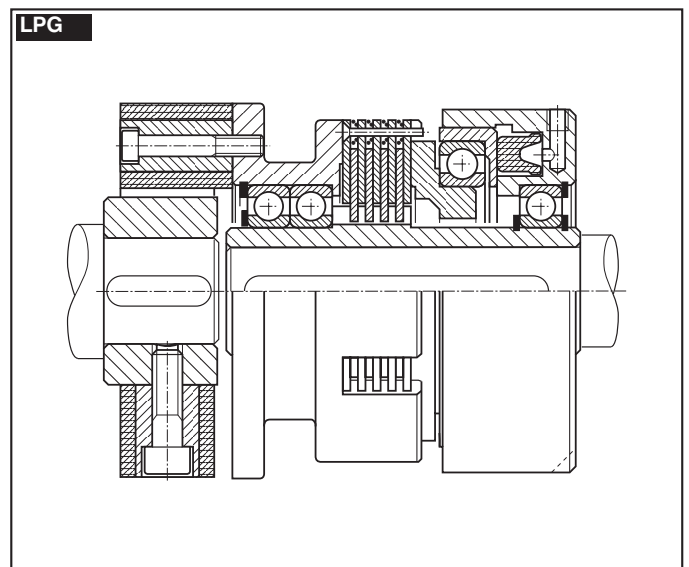
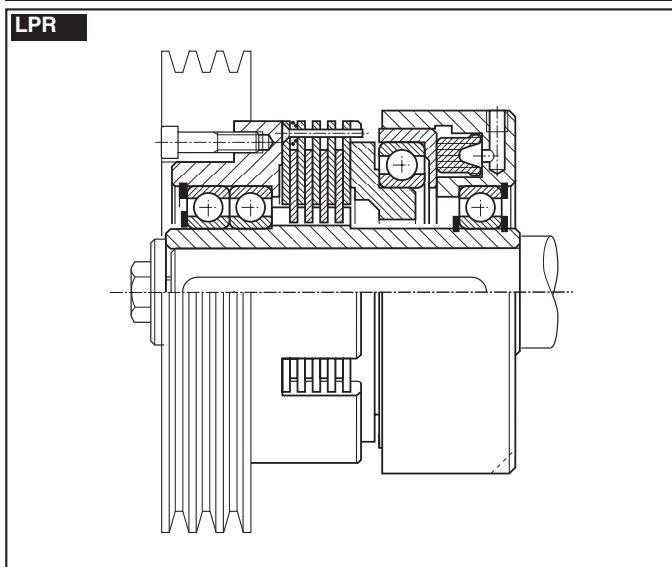

PNEUMATIC MULTIDISK CLUTCH WITH TRANSMISSION HUB

LPR...

03

MODEL	LPR □□□
CODE	03.06.□□□.01

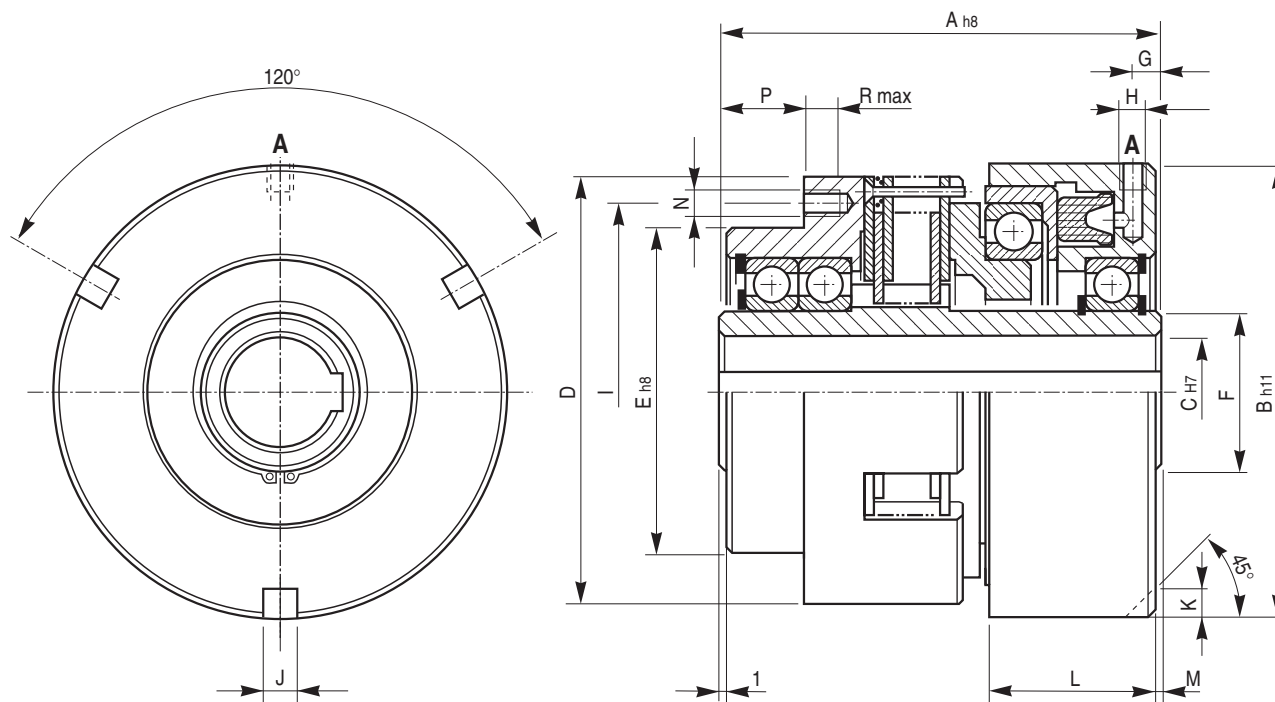

A = Alimentazione aria / Air supply

□□□	Mi (Nm)	Torques		Working pressure (bar)	Cylinder volume (cm ³)	R.P.M. limit max	Weight (kg)	Internal plates N.
		Ms (Nm)						
002	44	65		6	4	3000	3,2	4
003	75	114		6	6	2800	4,9	4
004	140	210		6	10	2400	6,2	5
006	330	460		6	16	2000	10,5	5
008	590	830		6	30	1800	16,1	6
010	1200	1700		6	50	1400	31	6

□□□	A	B	C		D	E	F	G	H	I	J x K	L	M	N	P	R
			min.	max.										n° x Ø		max.
002	100	97	12	22	89	62	30	7	1/8"	80	10 x 9	38	1	3 x M 6	22	11
003	110	115	16	26	104	70	35	7	1/8"	88	10 x 10	46	1	3 x M 6	23,5	11
004	118	127	18	34	116	84	45	7	1/8"	102	10 x 10	44	1	6 x M 6	28	10
006	130	153	20	46	145	105	60	9,5	1/4"	130	12 x 12	49	1,5	6 x M 6	34	10
008	150	167	25	50	179	112	65	9	1/4"	140	12 x 12	55	1	6 x M 8	36	12
010	175	216	30	68	218	145	85	9	1/4"	190	14 x 14	65	1	6 x M10	37	15