



## Airflex® Type CH Hydraulic Elements



### Element Description



### Type CH

Type CH elements are designed specifically for heavy duty clutch and brake applications. They can be air or hydraulically actuated. The friction disc packs are suitable for either wet or dry operation. Actuation is accomplished through internal shaft and clutch passages, similar to the Type AR. When used as a wet clutch, coolant oil is forced through the friction disc pack from an internal shaft passage.

The element hub is bored and keyseated for shaft mounting. Torque is transferred from the disc pack to a splined drive ring.

Type CH elements are available in six sizes with torque ratings to 1,038,000 lbin (117.200 N·m).

\*PolyPak is a registered trademark of Parker Seal Group.  
Nituff is a registered trademark of Nimet Industries, Inc.  
Teflon is a registered trademark of DuPont Fluorocarbon resins.  
Ionitriding is a registered trademark of Midland Ross Corporation.

Other design features include:

- Qualified for American Bureau of Shipping (ABS) Type Approval.
- Long-wearing, self-lubricating PolyPak\* seals eliminate premature twisting failure and requires no external lubrication.
- Nituff<sup>®</sup> coating, a Teflon\* impregnated hard coat anodizing, is used on the cylinder walls to create a self-lubricating surface to minimize wear and reduce corrosion.
- All splines processed with Ionitriding\* to retard wear and increase corrosion resistance.
- Sintered bronze friction material, operating in oil, provides a low static-to-dynamic torque ratio for smooth long-lasting, high energy performance.
- Mechanical lock-up screws.



# Airflex® Type CH Elements



## Component Parts

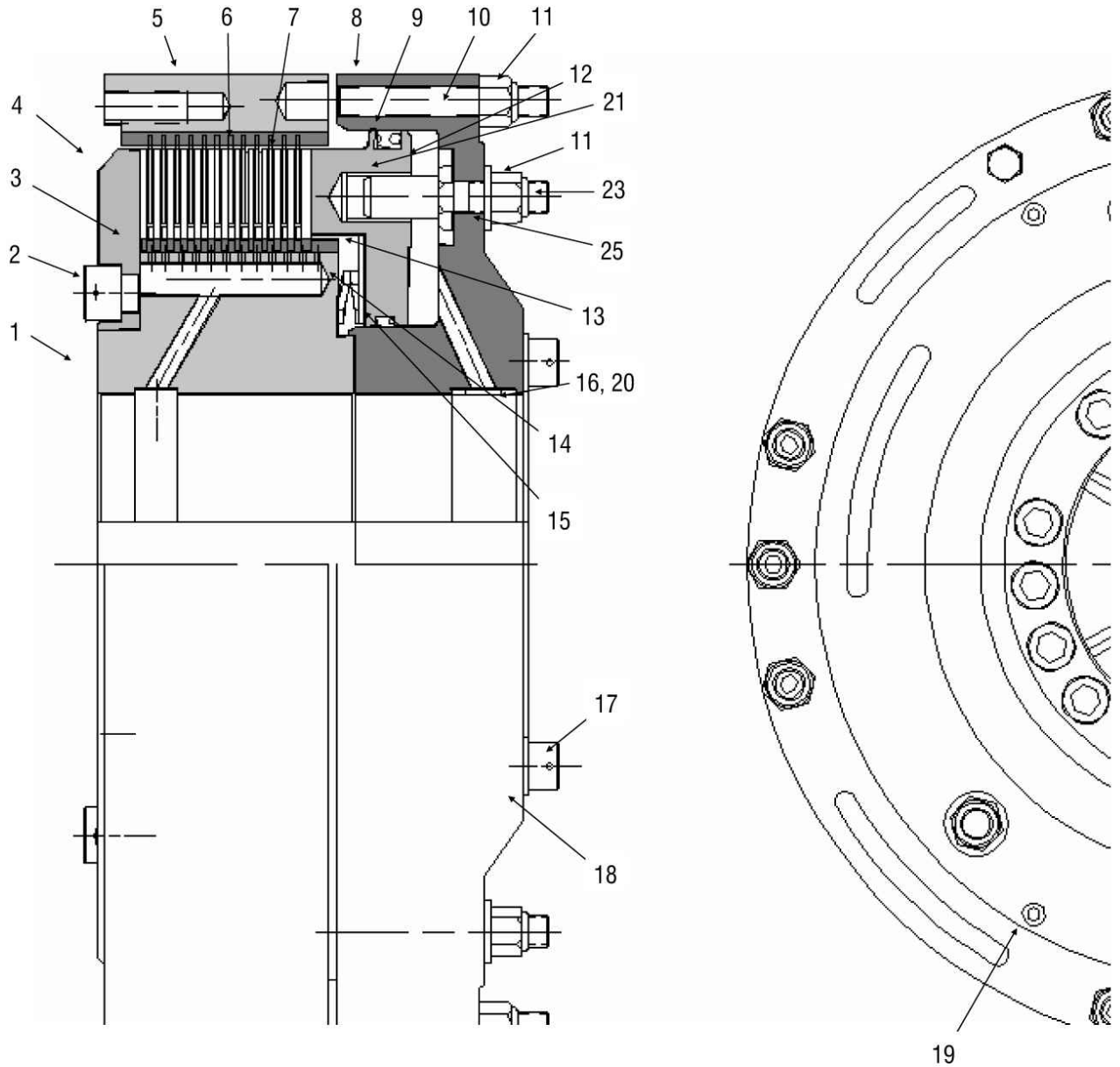

Item	Description
1	Hub
2	Socket Head Cap Screw
3	Separator Spring
4	End Plate
5	Drive Ring
6	Separator Disc
7	Friction Disc
8	Cylinder
9	Seal
10	Mechanical Lock-Up Screw
11	Locknut
12	Piston

Item	Description
13	Spring Retainer
14	Spring
15	Seal
16	Shaft Seal-Pressure
17	Socket Head Cap Screw
18	Clamp Plate
19	Pipe Plug
20	Shaft Seal-Balance
21	Bushing
23	Anti-Rotation Pin
25	Flat Washer



# Airflex® Type CH Elements



## Dimensional Data

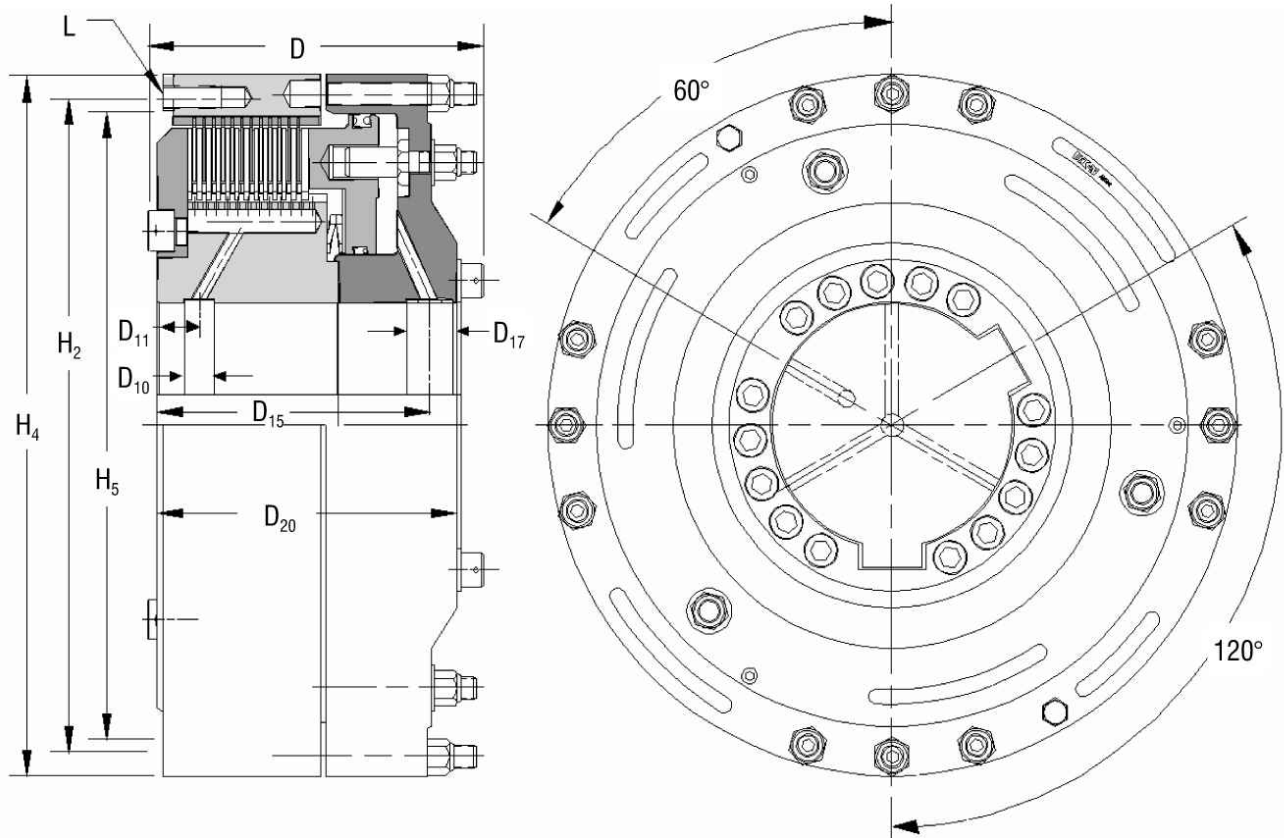

English		Dimensions in inches										
CH1050	3.38	7.88	.63	1.00	6.34	③	7.13	12.000	13.00	11.375	12	1/2-13
CH1250	4.50	8.75	.75	1.53	7.19	1.25	8.00	14.375	15.50	13.583	15	1/2-13
CH1440	5.25	10.37	.75	1.50	③	③	9.38	16.500	17.75	15.625	15	5/8-11
CH1640	6.25	10.62	.75	1.50	③	1.25	9.63	18.500	19.75	17.562	18	5/8-11
CH1940	8.00	11.16	1.25	1.50	9.07	1.50	9.98	21.500	23.00	20.625	15	3/4-10
CH2150	9.00	11.38	1.38	1.50	10.40	1.50	10.13	23.750	25.50	22.625	18	3/4-10
Size	Max. Bore	D	D <sub>10</sub>	② D <sub>11</sub>	② D <sub>15</sub>	D <sub>17</sub>	D <sub>20</sub>	H <sub>2</sub>	H <sub>4</sub>	H <sub>5</sub>	No. Size	
											① L	No. Size
CH1050	86	200	16	25	161	③	181	304,8	330	288,9	12	1/2-13
CH1250	114	222	19	39	182,6	31,8	203	365,1	394	345,0	15	1/2-13
CH1440	133	263	19	38	③	③	238	419,1	451	396,9	15	5/8-11
CH1640	159	270	19	38	③	31,8	244	469,9	502	446,1	18	5/8-11
CH1940	203	283	32	38	230,4	38,1	253	546,1	584	523,9	15	3/4-10
CH2150	229	289	35	43	264,2	38,1	257	603,3	648	574,7	18	3/4-10
SI	Dimensions in millimeters											

### Notes:

- ① American National Standard for Unified Screw Threads.
- ② The centerline location is based on the maximum bore diameter. This location will change with bore dimensions less than the maximum.
- ③ Contact factory for dimension.



# Airflex® Type CH Elements



## Technical Data

English	lb·ft <sup>2</sup>		lb			E + 08 lb/in/rad	in <sup>3</sup>		in <sup>2</sup>
	Drive Ring	Hub & Cylinder	Drive Ring	Hub & Cylinder	Total		New	Worn	
CH1050	2	5	50	87	137	4	32	60	772
CH1250	5	10	79	139	218	7	45	90	1013
CH1440	8	21	107	201	308	13	79	130	1194
CH1640	12	36	133	287	420	18	101	166	1631
CH1940	20	68	175	402	577	33	143	301	2061
CH2150	34	102	228	486	714	47	185	390	3104
Size	Wk <sup>2</sup>		Weight			Torsional Stiffness	Cylinder Volume ⑤		Friction Area
	J	④	Mass						
CH1050	0,08	0,21	23	39	62	0,452	0,52	0,98	4981
CH1250	0,21	0,42	36	63	99	0,791	0,74	1,48	6536
CH1440	0,34	0,88	48	91	140	1,47	1,29	2,13	7703
CH1640	0,50	1,51	60	130	190	2,03	1,66	2,72	10523
CH1940	0,84	2,86	79	182	261	3,73	2,34	4,93	13297
CH2150	1,43	4,28	103	220	323	5,31	3,03	6,39	20026
SI	Drive Ring	Hub & Cylinder	Drive Ring	Hub & Cylinder	Total	E + 08 N·m/rad	New	Worn	cm <sup>2</sup>
	kg·m <sup>2</sup>		kg				dm <sup>3</sup>		

### Notes:

- ① Dynamic torque shown. Static torque 25% greater.
- ② Based upon an ambient air temperature of 100°F (38°C). Speeds are at friction disc outside diameter. See Selection Procedure.
- ③ Coolant to be type C3 approved or EP oils suitable for CC or SE service within a viscosity range of SAE10 to SAE50W with no free chlorine or free sulphur. Thermal capacities based on 100°F (38°C) sump temperature and a maximum temperature rise of 100°F (55°C).
- ④ Based on maximum bore.
- ⑤ Absolute cylinder volume with new or worn friction linings.





# Airflex® Type CH Elements



Technical Data for Wet or Dry Operation

## Wet Operation

English	lb in @ 150 psi	rpm	rpm	ft lb/cycle	Typical		Maximum	
					HP	GPM	HP	GPM
CH1050	100000	2200	1000	400000	30	5	60	10
CH1250	180000	2000	1000	530000	40	7	80	14
CH1440	270000	1800	800	680000	52	9	104	18
CH1640	390000	1600	800	820000	64	11	128	22
CH1940	580000	1300	500	1130000	93	16	186	32
CH2150	830000	1200	400	1630000	134	23	268	46
Size	M <sub>r</sub> Torque Rating <sup>①</sup>	Maximum Speed	Maximum Disengaged Speed	Maximum Work/Cycle	Power	Oil Flow	Power	Oil Flow
					Clutch Thermal Capacity <sup>②</sup>			
					Power	Oil Flow	Power	Oil Flow
CH1050	11300	2200	1000	542000	22	19	45	38
CH1250	20300	2000	1000	719000	30	26	60	53
CH1440	30500	1800	800	922000	39	34	76	68
CH1640	44100	1600	800	1112000	48	42	95	83
CH1940	65500	1300	500	1532000	69	61	139	121
CH2150	93800	1200	400	2210000	100	87	200	174
SI	N·m @ 10,3 bar	rpm	rpm	joule/cycle	kW	dm³/m	kW	dm³/m
					Typical		Maximum	

## Dry Operation

English	lb in @ 90 psi	rpm	ft lb/cycle	HP					
CH1050	100000	2200	80000	1	5	11	1	3	8
CH1250	180000	1800	110000	1	6	15	1	4	10
CH1440	270000	1800	140000	2	8	19	1	5	13
CH1640	390000	1600	160000	2	10	23	1	6	16
CH1940	580000	1300	230000	3	14	32	2	9	21
CH2150	830000	1200	330000	4	20	46	3	13	31
Size	M <sub>r</sub> Torque Rating <sup>①</sup>	Max. Speed	Max. Work/cycle	1000 fpm	2000 fpm	3000 fpm	1000 fpm	2000 fpm	3000 fpm
				Clutch Thermal Capacity <sup>②</sup>			Brake Thermal Capacity <sup>②</sup>		
				5,08 mps	10,16 mps	15,24 mps	5,08 mps	10,16 mps	15,24 mps
CH1050	11300	2200	108000	0,75	3,7	8,2	0,75	2,2	6,0
CH1250	20300	1800	149000	0,75	4,5	11	0,75	3,0	7,5
CH1440	30500	1800	190000	1,5	6,0	14	0,75	3,7	9,7
CH1640	44100	1600	217000	1,5	7,5	17	0,75	4,5	12
CH1940	65500	1300	312000	2,2	10	24	1,5	6,7	16
CH2150	93800	1200	447000	3,0	15	34	2,2	9,7	23
SI	N·m @ 6,2 bar	rpm	joule/cycle	kW					