

**////// ZERO-MAX<sup>®</sup>**

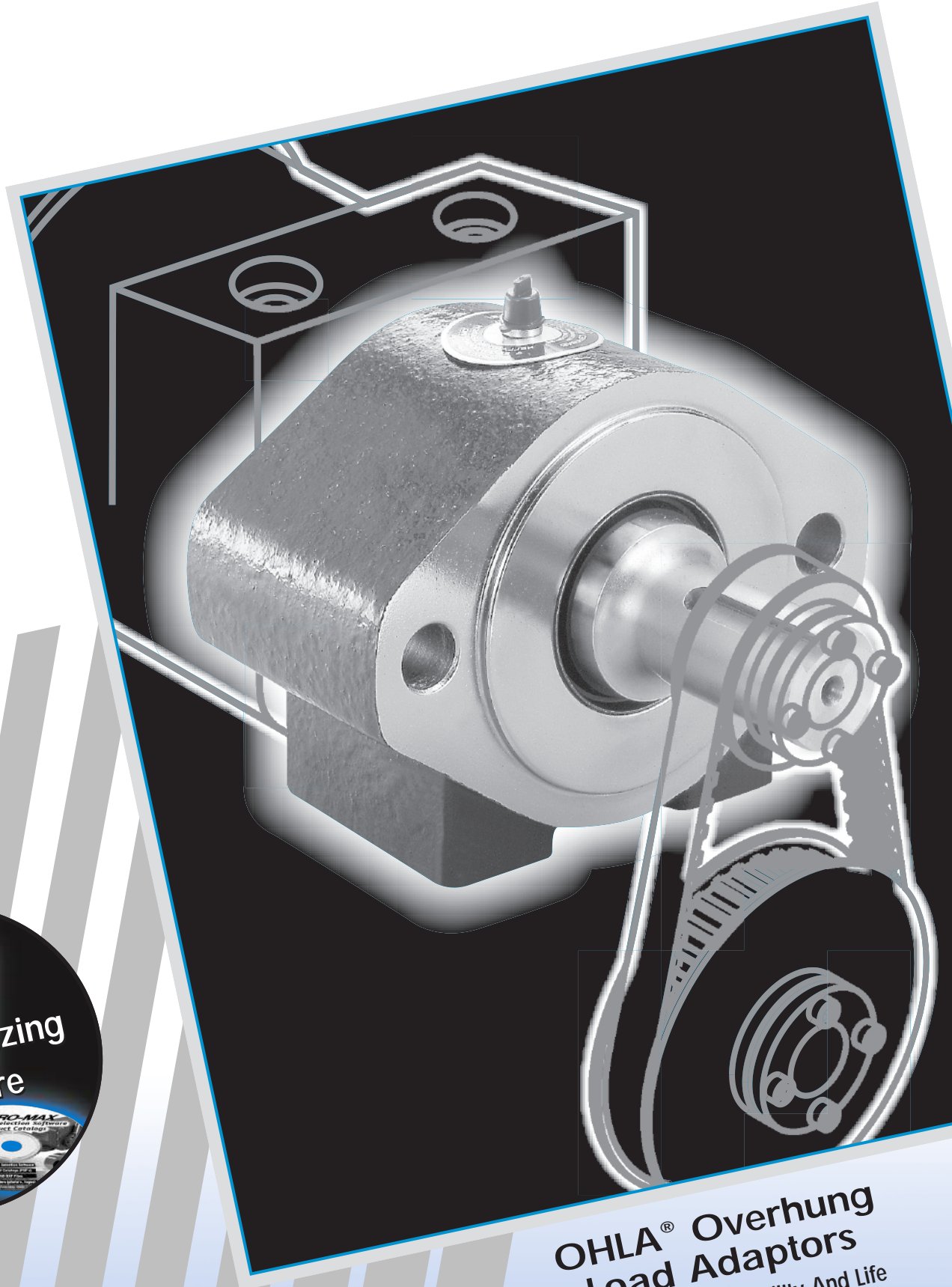

**OHLA<sup>®</sup> Overhung  
Load Adaptors**  
Increase Motor Durability And Life

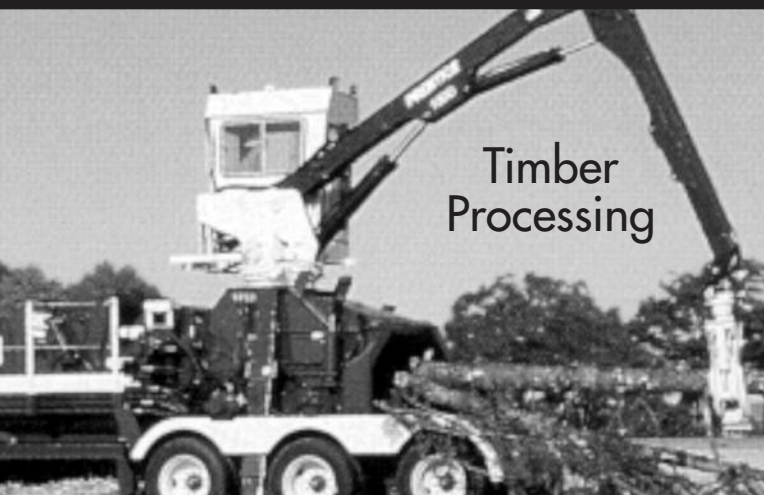

Timber Processing



Construction

# OHLA®

## OVERHUNG LOAD ADAPTORS

*ZERO-MAX Is A  
World-Leading Expert In  
Overhung Load Technology*

The first complete line of SAE "A" through SAE "F" mount OHLA overhung load adaptors was designed by ZERO-MAX. We set the industry standard with the OHLA design. Today, we provide immediate shipment of standard models from stock.

From the smallest Model 200 SAE "A" mount to the largest Model 1500 SAE "F" mount, OHLA's feature rugged housings of cast iron, shafts of 130,000 PSI stress-proof steel, ball or tapered-roller bearings, many different shaft options and attractively painted housings. All models may be either face or foot-mounted.

We offer many custom options or we'll create a special design for your application when needed.

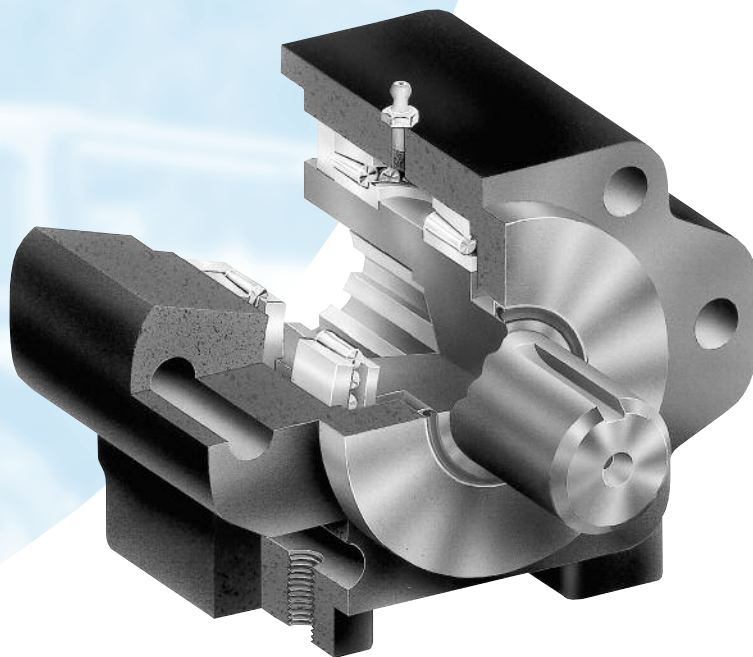

### *Count On OHLA's For These Important Benefits:*

- Eliminates premature motor or pump failure due to overhung loads (axial and radial) on your motor or pump shaft.
- Prevents contamination of hydraulic fluid in harsh environments.
- Provides a solid, permanent mounting surface.
- Permits the removal of hydraulic motors for servicing without disturbing driven gears, pulleys or sprockets.
- Seals out dirt and grime.

*Call a ZERO-MAX technical sales representative now. There's a model and size OHLA to handle every design need—or we'll engineer a special one just for you. 1-800-533-1731*



Recycling



Forestry

**Model 200 SAE "A" Mount**

Applications utilizing SAE "A" 2-bolt mount with ball bearings for motor or pump shafts up to 1 inch in diameter (see page 4).



**Model 300 SAE "A" Mount**

SAE "A" 2-bolt mount with same mounting dimensions as Model 200, but utilizes larger ball bearings which allow for heavier overhung loads and a larger input bore diameter (up to 1.25") (see page 5).



**Model 400**

4-bolt mounting (non-SAE) accommodates same loads as the Model 200 with ball bearings for motor and pump shafts up to 1 inch in diameter (see page 6).



**Model 500 SAE "A" Mount**

SAE "A" 4-bolt mount, which uses tapered-roller bearings. Standard input bores include: 1-1/4" keyed, 1"-6B spline, or 14 tooth 12/24 spline (see page 7).



**Model 600 SAE "B" Mount**

SAE "B" 2- or 4-bolt mount using tapered-roller bearings. Standard input bores include: 7/8", 1", or 1-1/4" keyed; 13 tooth 16/32 spline, or 15 tooth 16/32 spline. Also available with 1" keyed through-bore as a standard (see page 8).



**Model 800 SAE "C" Mount**

SAE "C" 2- or 4-bolt mount using tapered-roller bearings. Standard input bores include: 7/8", 1", or 1-1/4" keyed; 14 tooth 12/24 spline. Also available with 1" keyed through-bore as a standard (see page 9).



**Model 900 SAE "C-C" Mount**

SAE "C" 2- or 4-bolt mount with same mounting dimensions as the Model 800, but using larger tapered-roller bearings which allow for heavier overhung loads and a larger input bore diameter. Standard input bores include: 1-1/2", or 1-3/4" keyed; 14 tooth 12/24 spline, or 17 tooth 12/24 spline (see page 10).



**Model 1100 SAE "D" Mount**

SAE "D" mount using large tapered-roller bearings for heavy-duty applications. Standard input bores include: 1-3/4" keyed, or 13 tooth 8/16 spline (see page 11).



**Model 1250 SAE "E" Mount & Model 1500 SAE "F" Mount**

Both the SAE "E" and SAE "F" mounts have the same physical size; only the pilot diameter and bolt circle are different for motor or pump mounting. These models use large spherical-roller bearings for heavy-duty applications. Input bores are made to customer specifications up to a 2-1/2" diameter (see page 12).



**Custom Models**

Modified dimensions and special features are available (see page 13).

# OHLA<sup>®</sup> 200

## OVERHUNG LOAD ADAPTORS

- For SAE "A" 2-bolt mount applications with motor or pump shafts up to 1" diameter.
- Features deep-grooved ball bearings.
- Accepts speeds up to 4400 RPM with proper lubrication. See Page 15.

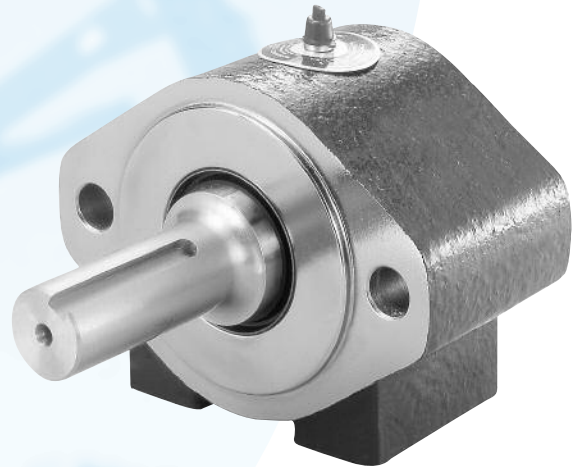

### STANDARD MODELS

Model*	Output Shaft - Keyway	Input Bore - Keyway
210	1.00 - 1/4 x 1/8	1.00 - 1/4 x 1/8
210F	1.00 Bore - 1/4 x 1/8	1.00 - 1/4 x 1/8
215	1.50 - 3/8 x 3/16	1.00 - 1/4 x 1/8
210-10	1.00 - 1/4 x 1/8	.625 - 5/32 x 5/64
210-12	1.00 - 1/4 x 1/8	.750 - 3/16 x 3/32
215-12	1.50 - 3/8 x 3/16	.750 - 3/16 x 3/32

\*0.125 Pilot depth is Standard. Add "DP" to Model Number for a Deep Pilot. (0.25) Example: 210-DP

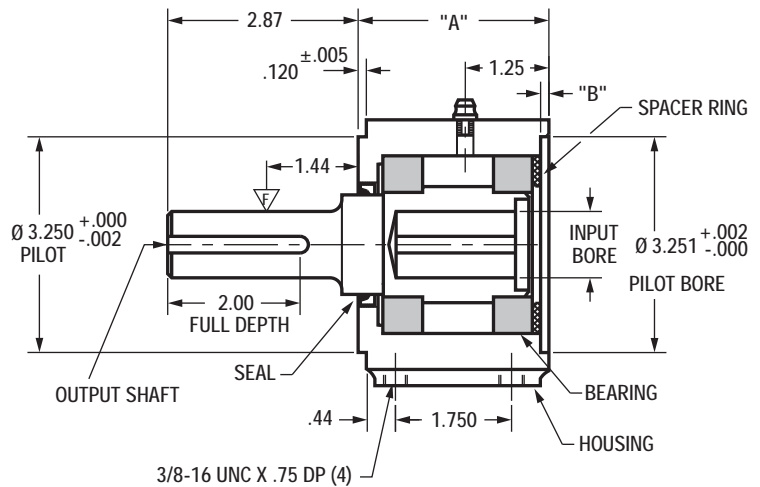
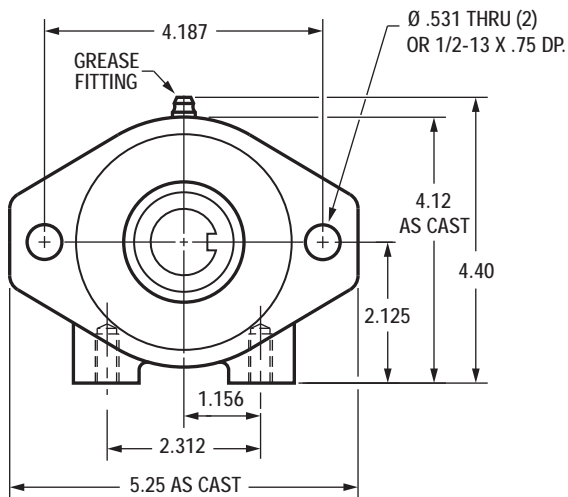

	"A"	"B"
STANDARD HOUSING	2.875	.125 +.005 -.000
DEEP PILOT HOUSING	3.000	.250 +.005 -.000

# OHLA<sup>®</sup> 300

## OVERHUNG LOAD ADAPTORS



- For SAE "A" 2-bolt mount for medium to heavy-duty applications.
- Features deep-grooved ball bearings.
- Featuring the same overall size as the Model 200, the Model 300 has larger bearings for heavy-duty applications.
- Accepts speeds up to 3550 RPM with proper lubrication. See Page 15.

### STANDARD MODELS

Model*	Output Shaft - Keyway	Input Bore - Keyway
312	1.25 - 5/16 x 5/32	1.25 - 5/16 x 5/32
315	1.50 - 3/8 x 3/16	1.25 - 5/16 x 5/32
300F	1.25 Bore - 5/16 x 5/32	1.25 - 5/16 x 5/32

\*0.125 Pilot depth is Standard. Add "DP" to Model Number for a Deep Pilot. (0.25) Example: 312-DP

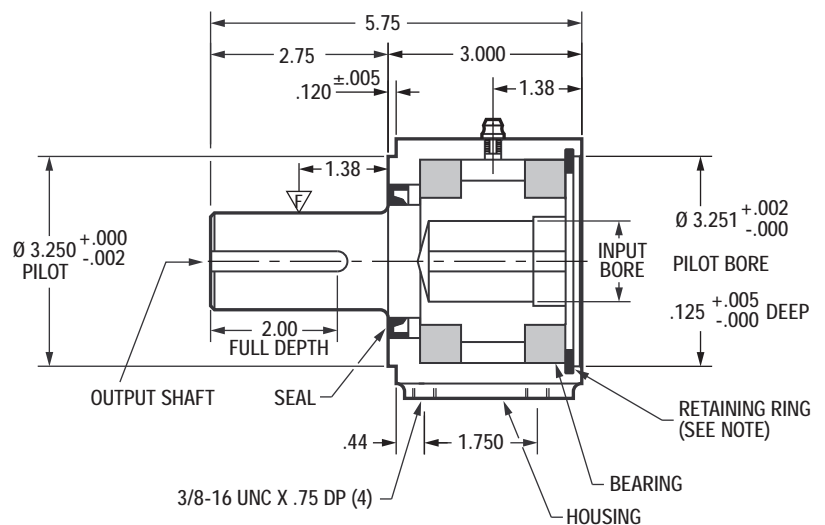
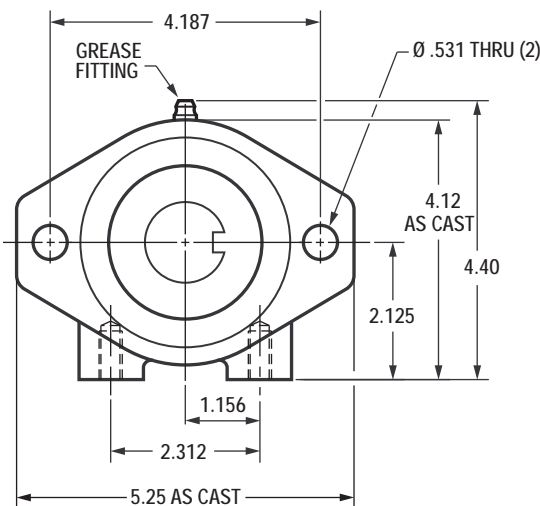

NOTE: FOR .250 DEEP PILOT  
RETAINING RING IS REMOVED

# OHLA<sup>®</sup> 400

## OVERHUNG LOAD ADAPTORS

- For applications with motor or pump shafts up to 1" diameter.
- Features deep-grooved ball bearings.
- Accepts speeds up to 4400 RPM with proper lubrication. See Page 15.

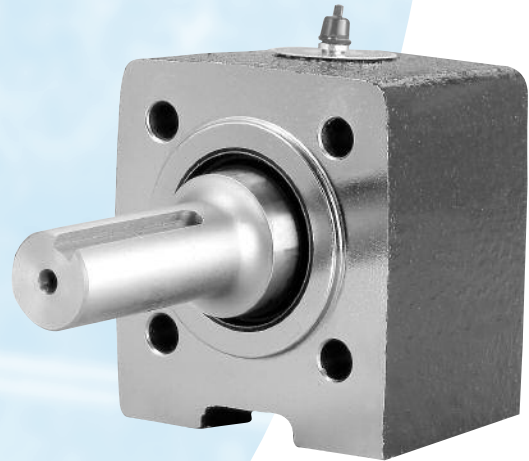

### STANDARD MODELS

Model	Output Shaft - Keyway	Input Bore - Keyway
410	1.00 - 1/4 x 1/8	1.00 - 1/4 x 1/8
410F	1.00 Bore - 1/4 x 1/8	1.00 - 1/4 x 1/8
415	1.50 - 3/8 x 3/16	1.00 - 1/4 x 1/8

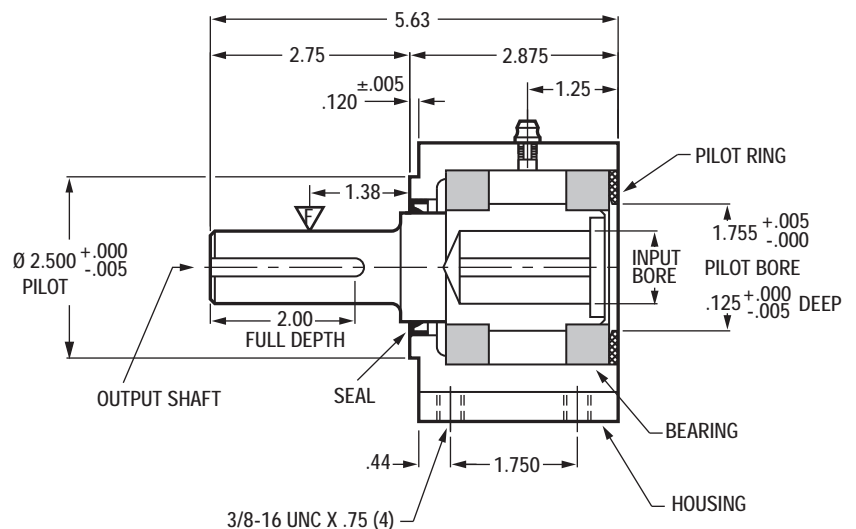
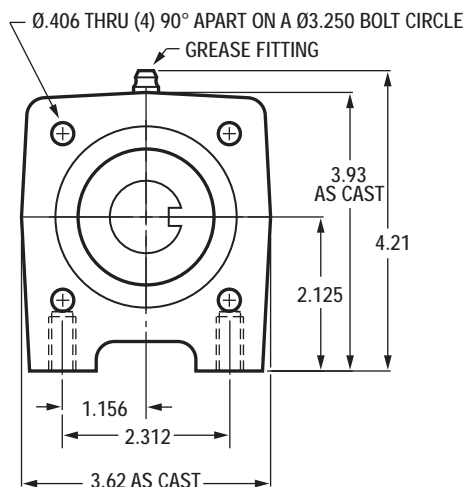

# OHLA<sup>®</sup> 500

## OVERHUNG LOAD ADAPTORS

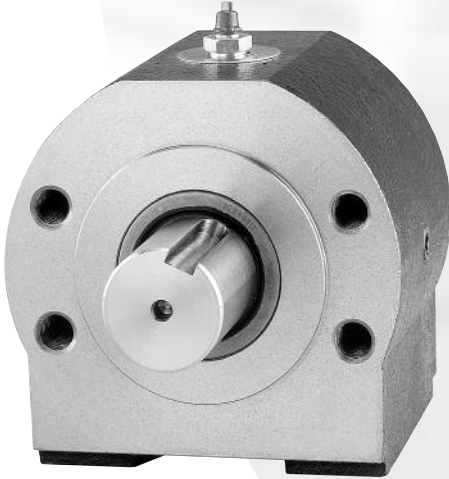

- For SAE "A" heavy-duty bearing block applications with 4-bolt mounting.
- Features heavy-duty tapered roller bearings.
- May be used on 2-bolt mount by tilting 22-1/2°.
- Accepts speeds up to 3300 RPM with proper lubrication. See Page 15.

### STANDARD MODELS

Model	Output Shaft - Keyway	Input Bore - Keyway
512-20	1.250 - 5/16 x 5/32	1.250 - 5/16 x 5/32
512-6BS	1.250 - 5/16 x 5/32	1.000 6B Spline
512-14S	1.250 - 5/16 x 5/32	14 Tooth 12/24 Spline
515-20	1.500 - 3/8 x 3/16	1.250 - 5/16 x 5/32
515-6BS	1.500 - 3/8 x 3/16	1.000 6B Spline
515-14S	1.500 - 3/8 x 3/16	14 Tooth 12/24 Spline

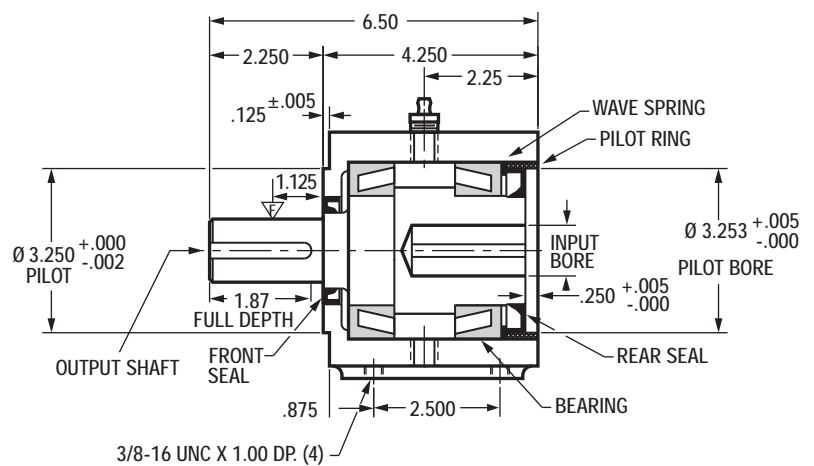
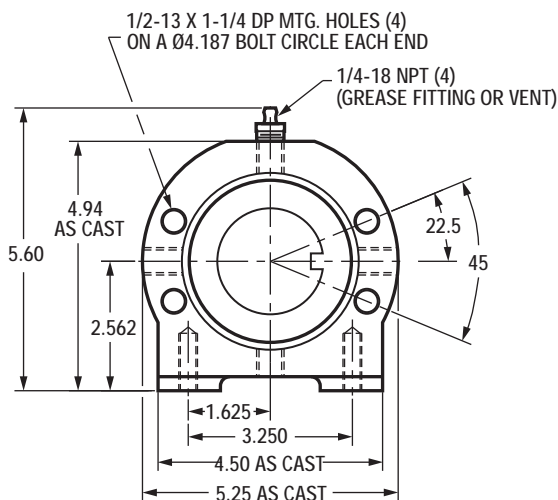

# OHLA<sup>®</sup> 600

## OVERHUNG LOAD ADAPTORS

- For SAE "B" mount motor or pump applications.
- Features heavy-duty tapered roller bearings.
- Accepts speeds up to 3300 RPM with proper lubrication. See Page 15.

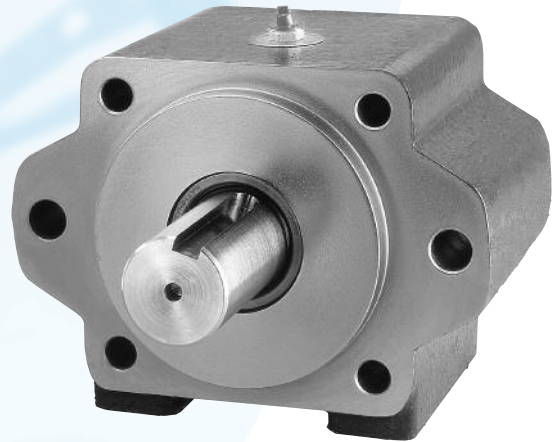

### STANDARD MODELS

Model	Output Shaft - Keyway	Input Bore - Keyway
615-13S	1.500 - 3/8 x 3/16	13 Tooth 16/32 Spline
615-15S	1.500 - 3/8 x 3/16	15 Tooth 16/32 Spline
615-14	1.500 - 3/8 x 3/16	.875 - 1/4 x 1/8*
615-16	1.500 - 3/8 x 3/16	1.000 - 1/4 x 1/8**
615-20	1.500 - 3/8 x 3/16	1.250 - 5/16 x 5/32
600F-16	1.00 Bore - 1/4 x 1/8	1.00 - 1/4 x 1/8

\*3/16 Keyway Optional  
\*\*5/16 Keyway Optional

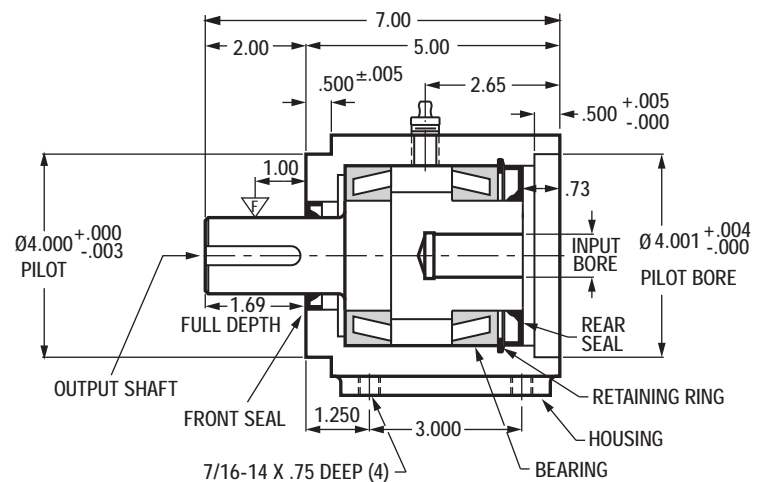
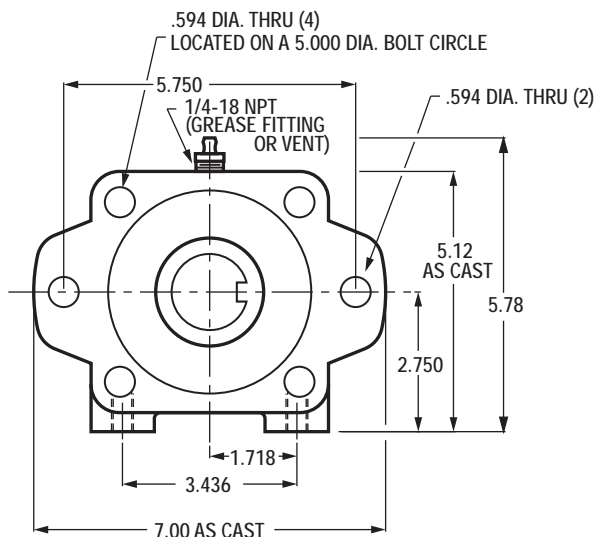

# OHLA<sup>®</sup> 800

## OVERHUNG LOAD ADAPTORS



- For SAE "C" mount motor or pump applications.
- Features heavy-duty tapered roller bearings.
- Accepts speeds up to 3300 RPM with proper lubrication. See Page 15.

### STANDARD MODELS

Model	Output Shaft - Keyway	Input Bore - Keyway
815-14S	1.500 - 3/8 x 3/16	14 Tooth 12/24 Spline
815-14	1.500 - 3/8 x 3/16	.875 - 1/4 x 1/8*
815-16	1.500 - 3/8 x 3/16	1.000 - 1/4 x 1/8**
815-20	1.500 - 3/8 x 3/16	1.250 - 5/16 x 5/16
800F-16	1.00 Bore - 1/4 x 1/8	1.00 - 1/4 x 1/8

\*3/16 Keyway Optional  
\*\*5/16 Keyway Optional

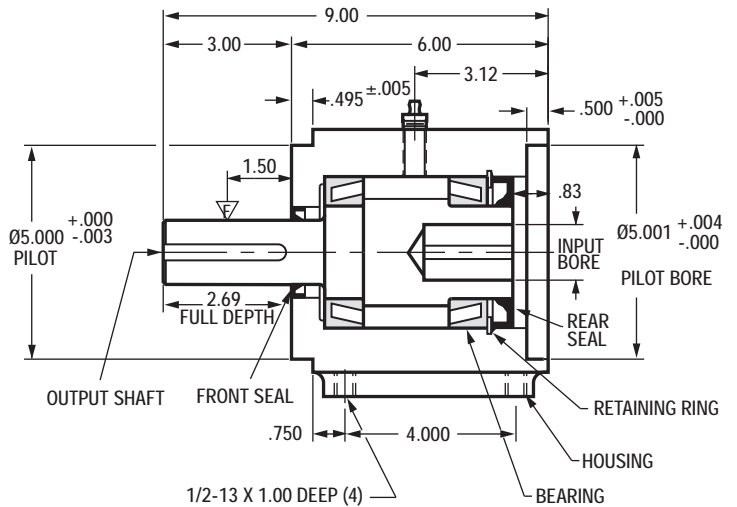
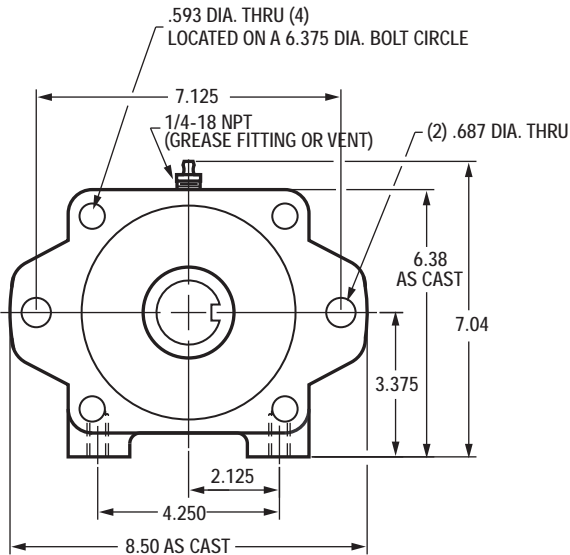

# OHLA<sup>®</sup> 900

## OVERHUNG LOAD ADAPTORS

- For SAE "C-C" mount motor or pump applications.
- Features heavy-duty tapered roller bearings.
- Accepts speeds up to 2700 RPM with proper lubrication. See Page 15.

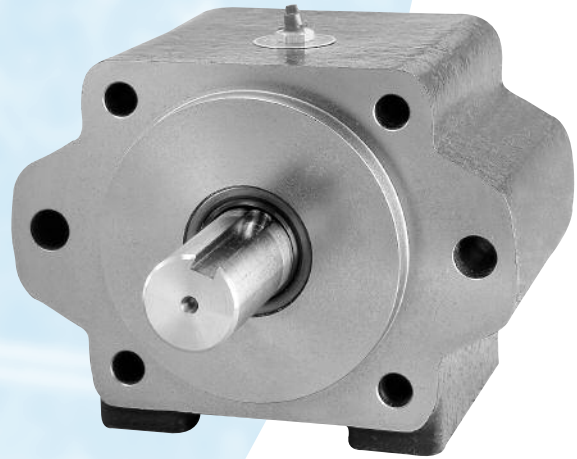

### STANDARD MODELS

Model	Output Shaft - Keyway	Input Bore - Keyway
915-14S	1.500 - 3/8 x 3/16	14 Tooth 12/24 Spline
915-17S	1.500 - 3/8 x 3/16	17 Tooth 12/24 Spline
915-24	1.500 - 3/8 x 3/16	1.500 - 3/8 x 3/16
915-28	1.500 - 3/8 x 3/16	1.750 - 7/16 x 7/32
928-14S	1.750 - 7/16 x 7/32	14 Tooth 12/24 Spline
928-17S	1.750 - 7/16 x 7/32	17 Tooth 12/24 Spline
928-24	1.750 - 7/16 x 7/32	1.500 - 3/8 x 3/16
928-28	1.750 - 7/16 x 7/32	1.750 - 7/16 x 7/32

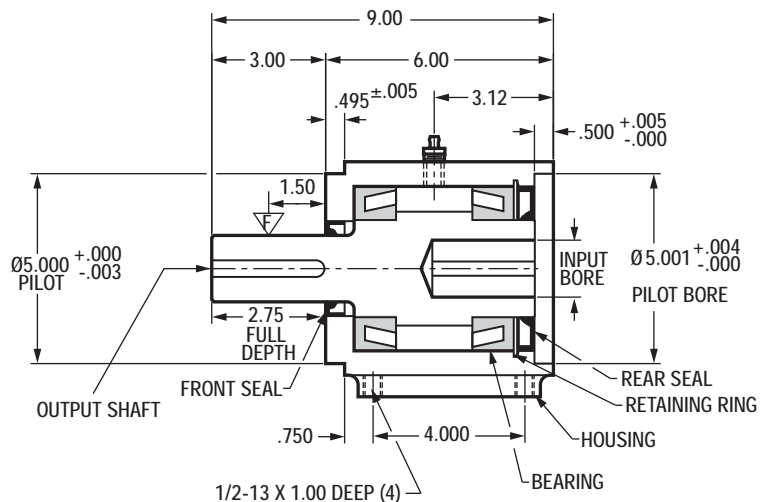
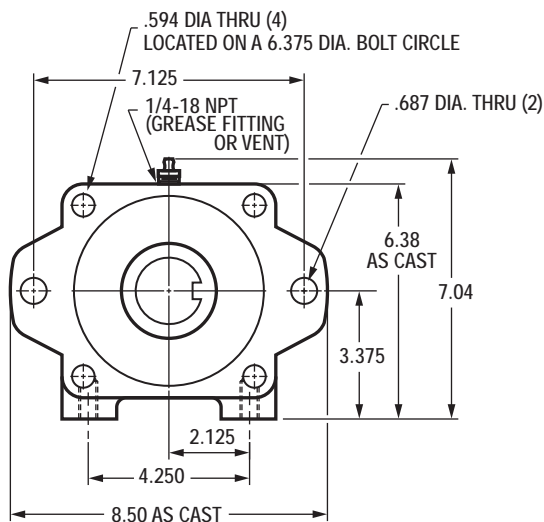

# OHLA<sup>®</sup> 1100

## OVERHUNG LOAD ADAPTORS



- For SAE "D" mount motor or pump applications.
- Features heavy-duty, tapered roller bearings.
- Accepts speeds up to 3500 RPM with proper lubrication. See Page 15.

### STANDARD MODELS

Model	Output Shaft - Keyway	Input Bore - Keyway
1136-28	2.250 - 1/2 x 1/4	1.750 - 7/16 x 7/32
1136-13S	2.250 - 1/2 x 1/4	13 Tooth 8/16 Spline

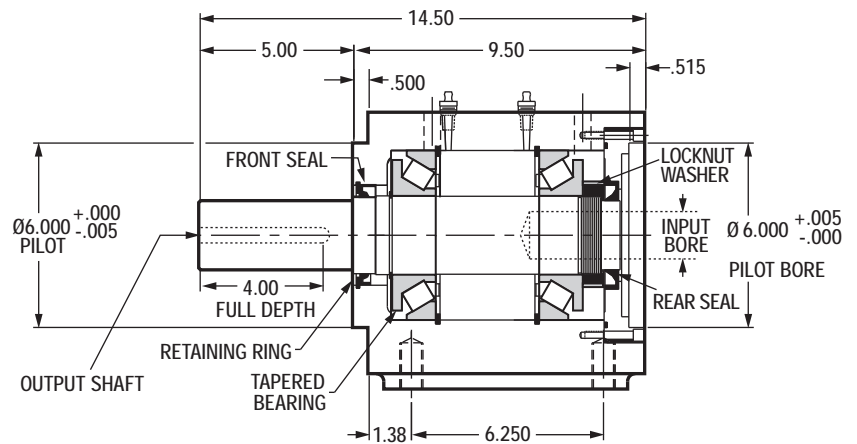
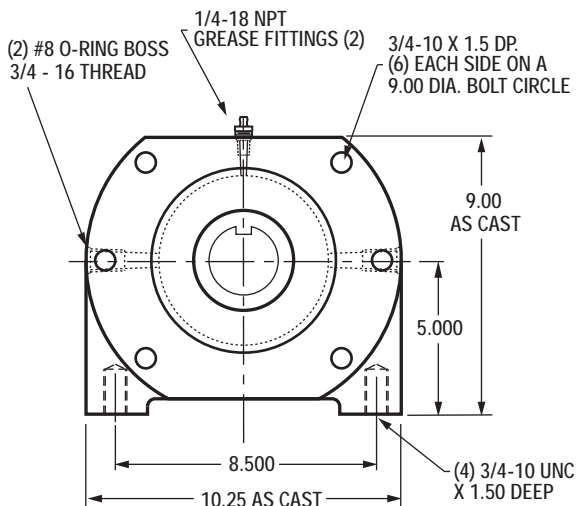



# OHLA<sup>®</sup> SPECIALS

OVERHUNG LOAD ADAPTORS

*There's a model and size Overhung Load Adaptor for your need...or we'll design one for you. In the U.S. call TOLL FREE 1-800-533-1731.*



- Special Input Bores
- Special Splines
- Output Diameter Changes
- Splined Output Shafts
- Threaded Output Shafts
- Tapered Output Shafts

- Extended Output Shafts
- O-ring Bosses
- Drilled And Tapped End Shafts
- Grease Fittings Or Vents
- Face Mounting Tapped Holes
- Magnetic Speed Sensor Modifications

- Special Shaft material And Heat Treating
  - High Pressure Seals
  - Housing Modifications
  - Special SAE Input Versus Output Mounting
- ... and many more!

# OHLA<sup>®</sup> SIZING AND SELECTING

## OVERHUNG LOAD ADAPTORS

1. Determine proper SAE flange mount for your application (SAE A, B, C, C-C, D, E, F)

2. Calculate the overhung load using the following formula:

$$\text{OHL (Overhung Load)} = \frac{63000 \times \text{HP} \times \text{F}}{\text{N} \times \text{R}}$$

HP = Transmitted Horsepower

N = RPM of Shaft

R = Radius of sprocket, pulley, etc. in inches

F = Load Connection Factor

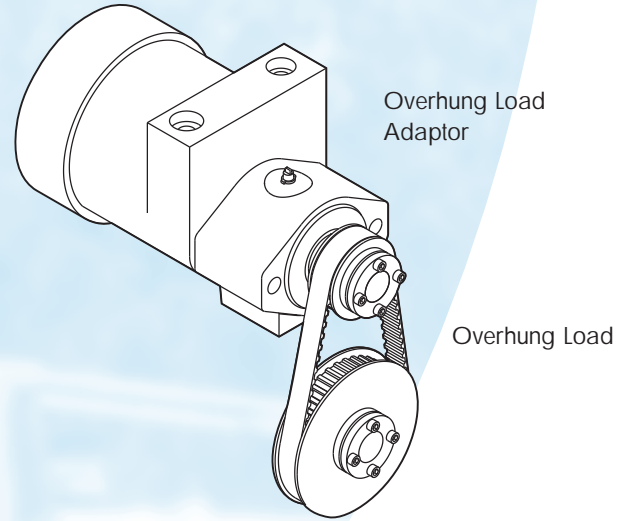

Load Connection Factor
1.00 - Single Chain Drives
1.25 - Spur or Helical Gear Drives or Double Chain Drives
1.50 - V-Belt Drives
2.00 - Timing Belt Drives
2.50 - Flat Belt Drives

3. Calculate bearing life of the selected model using the formulas from the following table:

### Note:

The bearing life calculations shown are to be used for radial loading only. Consult factory if more complex loading (Radial, Axial, Tangential) is present.

**Lubrication:** (See page 15)

### Specials

Your application may require a modified shaft or housing to fit an existing application or to simplify a new design. See "Options" (p 13).

Model	S	Calculated Life
200	$S = .603 X + 1.406$	$L_{10} = \frac{16,667}{\text{RPM}} \left( \frac{3,762}{S \cdot \text{OHL}} \right)^3$
300	$S = .606 X + 1.485$	$L_{10} = \frac{16,667}{\text{RPM}} \left( \frac{4,906}{S \cdot \text{OHL}} \right)^3$
400	$S = .603 X + 1.485$	$L_{10} = \frac{16,667}{\text{RPM}} \left( \frac{3,762}{S \cdot \text{OHL}} \right)^3$
500	$S = .704 X + 1.930$	$L_{10} = \frac{1,500,000}{\text{RPM}} \left( \frac{4,960}{S \cdot \text{OHL}} \right)^{3.33}$
600	$S = .714 X + 2.086$	$L_{10} = \frac{1,500,000}{\text{RPM}} \left( \frac{4,960}{S \cdot \text{OHL}} \right)^{3.33}$
800	$S = .448 X + 1.704$	$L_{10} = \frac{1,500,000}{\text{RPM}} \left( \frac{4,960}{S \cdot \text{OHL}} \right)^{3.33}$
900	$S = .442 X + 1.761$	$L_{10} = \frac{1,500,000}{\text{RPM}} \left( \frac{7,610}{S \cdot \text{OHL}} \right)^{3.33}$
1100	$S = .179 X + 1.285$	$L_{10} = \frac{1,500,000}{\text{RPM}} \left( \frac{12,000}{S \cdot \text{OHL}} \right)^{3.33}$
1250, 1500	$S = .219 X + 1.384$	$L_{10} = \frac{1,500,000}{\text{RPM}} \left( \frac{71,500}{S \cdot \text{OHL}} \right)^{3.33}$

X – Distance from front end of the OHLA housing to the applied radial load.

## VERTICAL APPLICATIONS

For applications where the shaft is vertical – consult factory for special bearing and lubrication requirements

# LUBRICATION

## HORIZONTAL APPLICATIONS

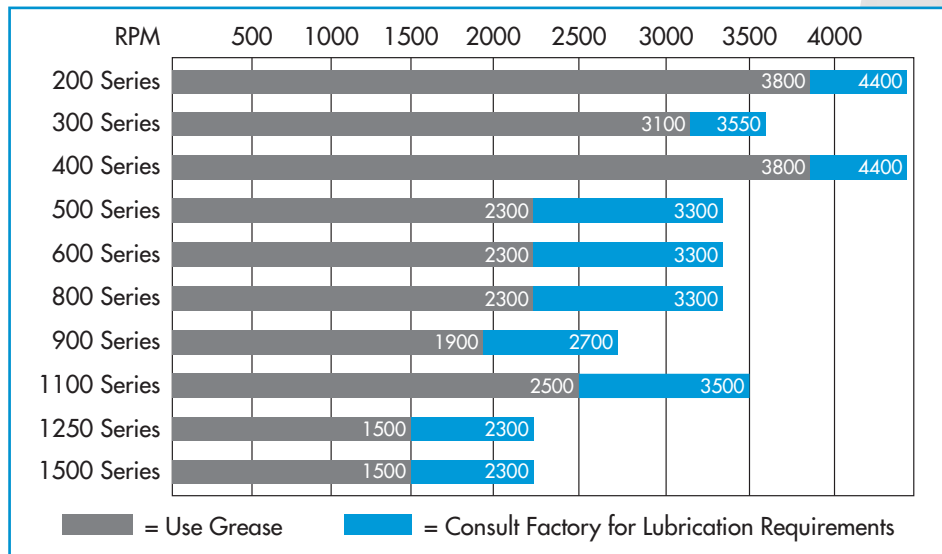

## GREASE CAPACITY

	Minimum	Maximum
200 Series	.5 oz.	1.0 oz.
300 Series	.7 oz.	1.4 oz.
400 Series	.4 oz.	1.0 oz.
500 Series	2.0 oz.	4.0 oz.
600 Series	2.2 oz.	4.4 oz.
800 Series	2.8 oz.	5.6 oz.
900 Series	4.3 oz.	8.6 oz.
1100 Series*	14.0 oz.	14.0 oz.
1250 Series	11.0 oz.	22.0 oz.
1500 Series	11.0 oz.	22.0 oz.

\*Per Grease Fitting

## GREASE TYPE

Indoor Conditions	NLGI #1 or NLGI #2
Outdoor Conditions	NLGI #1 or NLGI #2 (Synthetic Grease Recommended)
Severe Conditions	Consult Factory

## VERTICAL APPLICATIONS

For applications where the shaft is vertical – consult factory for special bearing and lubrication requirements

Visit the Zero-Max website for additional technical information at [www.zero-max.com](http://www.zero-max.com)

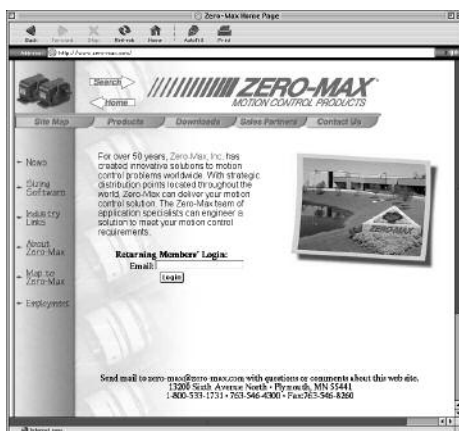

## Sizing software for Overhung Load Adaptors.

Zero-Max provides free software on a CD ROM to help select and size the correct Overhung Load Adaptor. This CD ROM contains all Zero-Max product catalogs in a PDF format, a comprehensive sizing and selection program and CAD drawings for most of the Zero-Max products.

The sizing and selection portion of the software walks the user through the selection of any Zero-Max product and gives a recommendation on which model to use.

The software is very user friendly and can be used on any Windows or Macintosh based computer.



# Additional Zero-Max® Motion Control Products

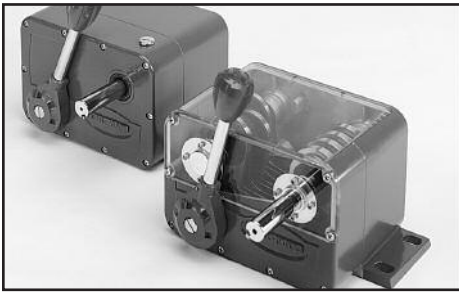

## Zero-Max® Adjustable Speed Drives

Variable 0 to 400 RPM outputs from constant input speeds to 2,000 RPM. Torques 12 to 200 in. lbs.



## ETP® Bushings

Locks hub to shaft easily without troublesome keys. 26 sizes from 3/4" to 4". Metrics from 8 mm to 100 mm. Stainless steel models.



## CD® Couplings

Patented open arm design uses composite disc. Single-flex, double-flex, double-flex spacer, and floating shaft models.



## Torq-Tender®

Accurate overload protection. Disengage torques to 3,000 in. lbs. Bores 1/8" to 1-3/4".



## Schmidt Couplings

Offset, In-line, Elastomeric and Control-Flex models. Sizes 5 to 500,000 inch lbs. torque.



## ServoClass® Couplings

Zero backlash, torsionally stiff, high misalignment. Clamp hubs. 9 sizes. Torques to 880 in-lb. Inch and metric bore.



## Posi-Lok Bushing®

Inch and Metric sizes to 35 mm. Nickel plating offers corrosion protection.

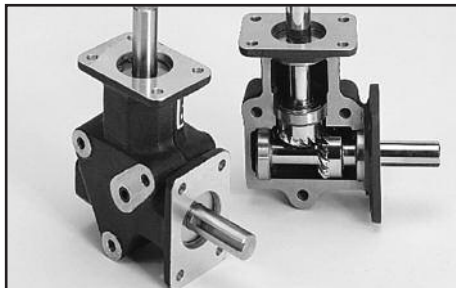

## Crown Right Angle Gear Drives

Two and three way models with 1:1 and 2:1 ratios. Spiral bevel gears. 3/8 to 1 inch dia. Stainless steel shafts.

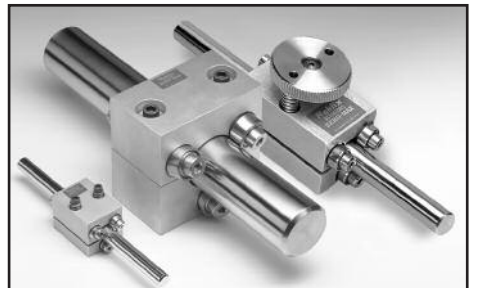

## Roh'lix® Linear Actuators

Convert rotary motion into precise linear motion. Five models with 3/8" to 2" dia. shafts. Thrust ratings to 200 lbs. Overload protection.

## WARRANTY

Zero-Max, Inc. the manufacturer, warrants that for a period of 12 months from date of shipment it will repair, or at its option, replace any new apparatus which proves defective in material or workmanship, or which does not conform to applicable drawings and specifications approved by the manufacturer. All repairs and replacements shall be F.O.B. factory. All claims must be made in writing to the manufacturer.

In no event and under no circumstances shall manufacturer be liable for (a) damages in shipment; (b) failures or damages due to misuse, abuse, improper installation or abnormal conditions of temperature, dirt, water or corrosives; (c) failures due to operation, intentional or otherwise, above rated capacities, and (d) non-authorized expenses for removal, inspection, transportation, repair or rework. Nor shall manufacturer ever be liable for consequential and incidental damages, or in any amount greater than the purchase price of the apparatus.

Zero Max, Inc. reserves the right to discontinue models or to change specifications at any time without notice. No discontinuance or change shall create any liability on the part of Zero-Max, Inc. in respect to its products in the hands of customers or products on order not incorporating such changes even though delivered after any such change.

This warranty is in LIEU OF ALL OTHER WARRANTIES, EXPRESS OR IMPLIED, INCLUDING (BUT NOT LIMITED TO) ANY IMPLIED WARRANTIES OF MERCHANTABILITY OR FITNESS FOR A PARTICULAR PURPOSE. THE TERMS OF THIS WARRANTY CONSTITUTE ALL BUYER'S OR USER'S SOLE AND EXCLUSIVE REMEDY, AND ARE IN LIEU OF ANY RIGHT TO RECOVER FOR NEGLIGENCE, BREACH OF WARRANTY, STRICT TORT LIABILITY OR UPON ANY OTHER THEORY. Any legal proceedings arising out of the sale or use of this apparatus must be commenced within 18 months of the date of purchase.

**CAUTION:** Rotating equipment must be guarded. Also refer to OSHA specifications and recommendations.

Zero-Max®, CD®, ETP®, ServoClass®, Torq-Tender®, Control-Flex®, Posi-Lok®, Roh'lix® and OHLA® are registered trademarks of Zero-Max, Inc.

© Zero-Max 2004 Printed in U.S.A.

# ////// ZERO-MAX®

13200 Sixth Avenue North, Plymouth, Minnesota 55441-5509  
800-533-1731 • (763) 546-4300 • Fax (763) 546-8260 • www.zero-max.com